

**738/YC3-RU/P/MS**

**特性 Features**

- 1、T-1 3/4普通圆柱形封装  
Popular T-1 3/4 round package
- 2、各种视角的选择  
Choice of various viewing angles
- 3、高可靠性  
Reliable and robust
- 4、可以编带或者转轴包装  
Available on tape and reel
- 5、产品完全符合RoHs标准  
The product itself will remain within RoHS compliant version
- 6、抗紫外线环氧树脂  
UV resisitant epoxy



**描述 Descriptions**

- 1、此系列专为高亮度需求应用设计  
The series is specially designed for applications requiring higher brightness.
- 2、此系列LED可以提供不同发光颜色、发光强度、胶体颜色  
The LED lamps are available with different colors, intensities, epoxy colors, etc.

**应用范围 Applications**

- 1、状彩色图形标志  
Color Graphic Signs
- 2、情报板  
Message boards
- 3、可变信息情报板  
Variable message signs (VMS)
- 4、户外商业广告屏  
Commercial outdoor advertising

**Device Selection Guide**

芯片 Chip		胶体颜色 Lens Color
材质 Material	发光颜色 Emitted Color	
磷化铝钾铟 AlGaInP	黄光 Brilliant Yellow	无色透明 Water Clear

**738/YC3-RU/P/MS**

封装尺寸 Package Dimensions

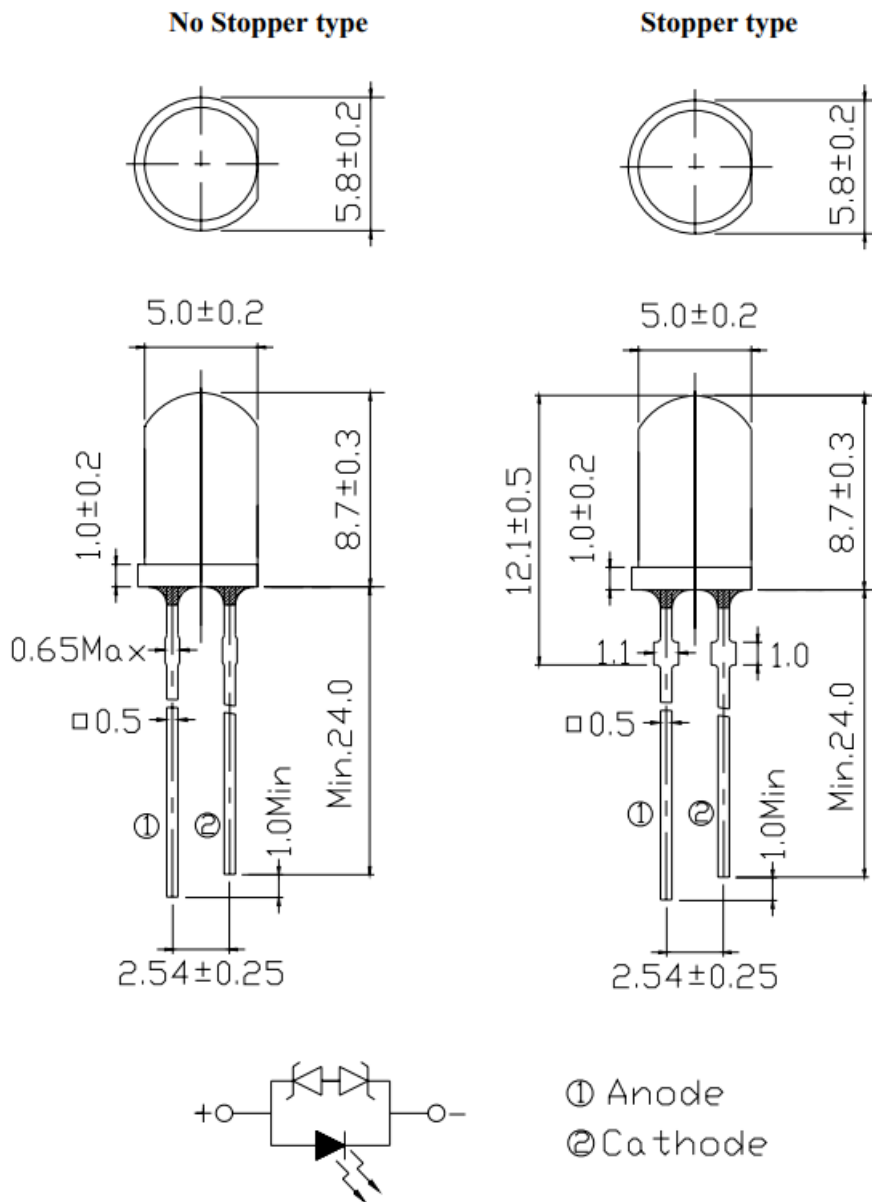

Notes:

- 1、所有尺寸单位为：mm，公差为 $\pm 0.25$ mm；指定除外。  
All dimensions are in millimeters, tolerance is 0.25mm except being specified.
- 2、胶体底部与引脚处多胶 最大不超过1.5mm。  
Protruded resin under flange is 1.5mm Max LED.

# 738/YC3-RU/P/MS

### ● 极限参数(Ta=25°C)

#### Absolute Maximum Rating (Ta=25°C)

参数名称 Parameter	符号 Symbol	最大极限数值 Absolute Maximum Rating	单位 Unit
正向电流 Forward Current	I <sub>F</sub>	25	mA
脉冲电流 Pulse Forward Current (Duty1/10@ 1KHz)	I <sub>FP</sub>	160	mA
工作温度 Operating Temperature	T <sub>opr</sub>	-25 ~ +85	°C
储存温度 Storage Temperature	T <sub>stg</sub>	-25 ~ +85	°C
焊接温度 Soldering Temperature	T <sub>sol</sub>	260	°C
功耗 Power Dissipation	P <sub>d</sub>	115	mW
反向电压 Reverse Voltage	V <sub>R</sub>	5	V
抗静电 Electrostatic Discharge	ESD	2K	V

提示 (Notes) : 焊接时间不可以超过 5 秒 (Soldering time ≤ 5 seconds)。

### ● 光电特性(Ta=25°C)

#### Electro-Optical Characteristics (Ta=25°C)

参数名称 Parameter	符号 Symbol	最小 Min.	规格 Typ.	最大 Max.	单位 Unit	测试条件 Condition
光强 Luminous Intensity	I <sub>v</sub>	4500	6000	--	mcd	I <sub>F</sub> =20mA
可视角度 Viewing Angle	2θ <sub>1/2</sub>	--	30	--	deg	
波峰值 Peak Wavelength	λ <sub>p</sub>	--	593	--	nm	
主波长 Dominant Wavelength	λ <sub>d</sub>	586	591	594		
半波宽 Spectrum Half width	Δλ	--	15	--		
正向电压 Forward Voltage	V <sub>F</sub>	1.8	--	2.6	V	
反向电流 Reverse Current	I <sub>R</sub>	--	--	10	μA	V <sub>R</sub> =5V

# 738/YC3-RU/P/MS

### ● 光强度等级范围

#### Bin Range of Luminous Intensity

等级 Bin Code	最小值 Min	最大值 Max	单位 Unit	测试条件 Condition
R	4500	5400	mcd	I <sub>F</sub> =20mA
S	5400	6500		
T	6500	7800		
U	7800	9300		

\*Measurement Uncertainty of Luminous Intensity:  $\pm 5\%$

### ● 波长等级范围

#### Bin Range of Dominant Wavelength

等级 Bin Code	最小值 Min	最大值 Max	单位 Unit	测试条件 Condition
a	586	590	nm	I <sub>F</sub> =20mA
b	590	594		

\*Measurement Uncertainty of Dominant Wavelength  $\pm 1.0\text{nm}$

### ● 电压等级范围

#### Bin Range of Forward Voltage

等级 Bin Code	最小值 Min	最大值 Max	单位 Unit	测试条件 Condition
V1	1.8	2.0	V	I <sub>F</sub> =20mA
V2	2.0	2.2		
V3	2.2	2.4		
V4	2.4	2.6		

\*Measurement Uncertainty of Forward Voltage:  $\pm 0.1\text{V}$

# 738/YC3-RU/P/MS

### ● 典型特性曲线

### Typical Electro-Optical Characteristics Curves

Relative Intensity vs. Wavelength

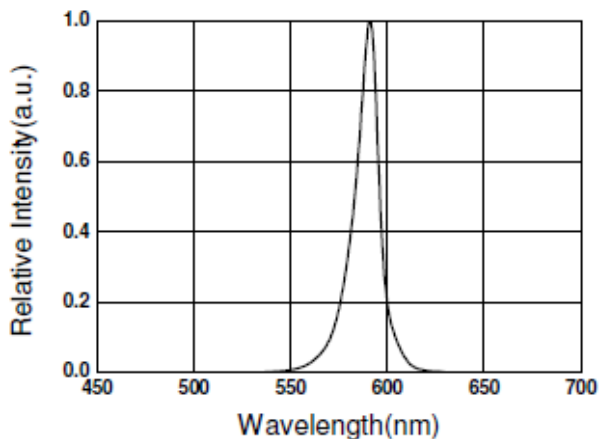

Forward Current vs. Forward Voltage

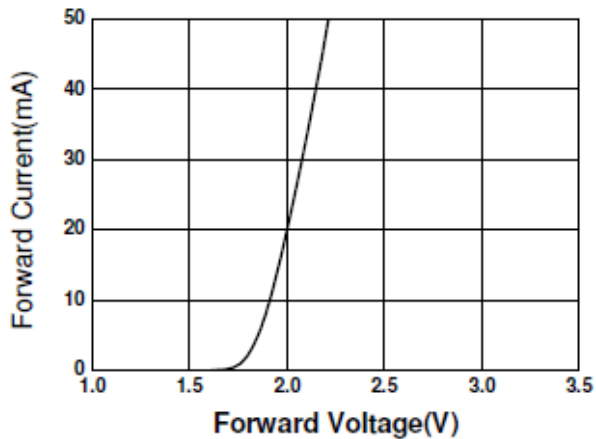

Relative Intensity vs. Ambient Temp.

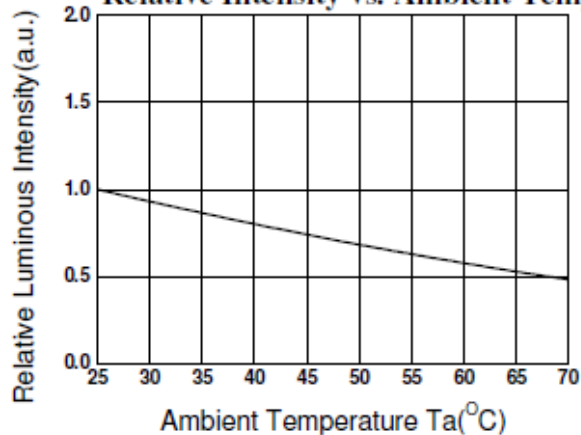

Relative Intensity vs. Forward Current

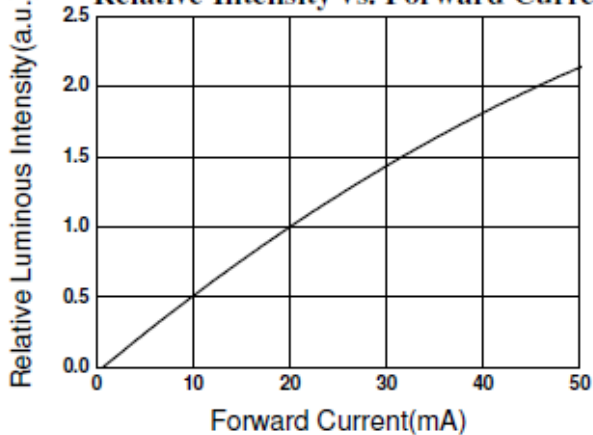

Forward Current vs. Ambient Temp.

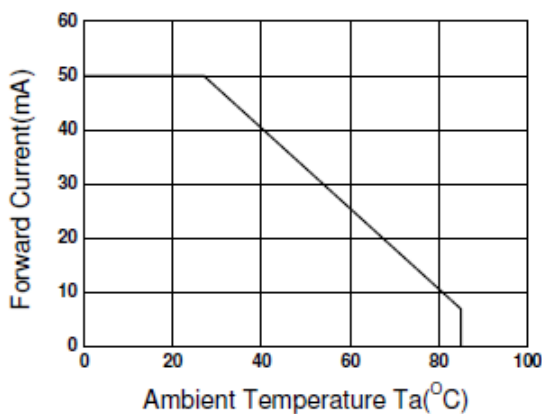

Radiation Characteristics

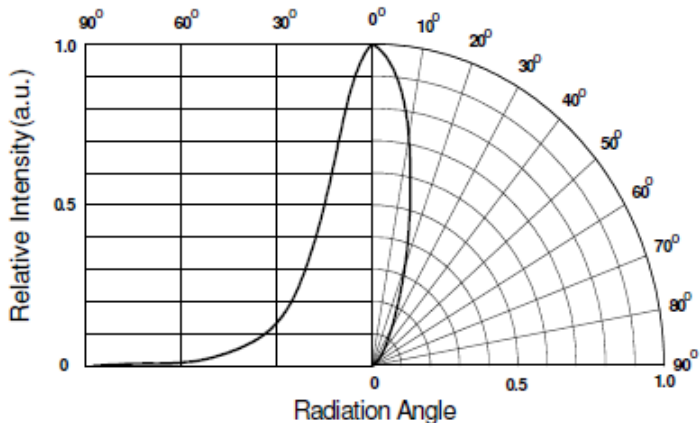

# 738/YC3-RU/P/MS

## 包装规格说明 Packing Specification

### 静电包装袋 Anti-electrostatic bag

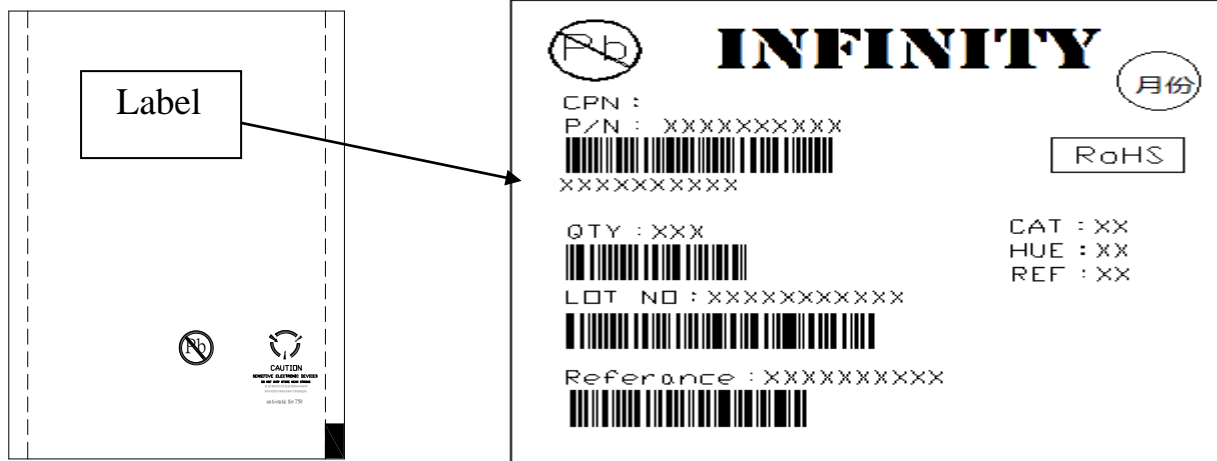

### 包装试样说明 Label Form Specification

- CPN: 客户物料编号 Customer's Production Number
- P/N: 英斐利物料代码 Production Number
- QTY: 包装数量 Packing Quantity
- CAT: 光强等级范围 Ranks of Luminous Intensity and Forward Voltage
- HUE: 波长等级范围 Rank of Dominant Wavelength
- REF: 追踪代码 Reference
- LOT No: 批次号 Lot Number

### 包装数量说明 Packing Quantity

- 1、 内盒 5\*500pcs/袋  
500pcs/bag, 5bag /1 Inner Carton
- 2、 一箱包含 10 小盒  
10 Inner Cartons/1 Outside Carton

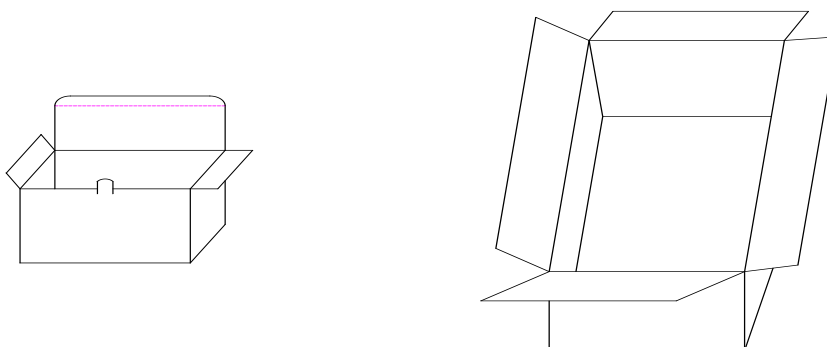

# 738/YC3-RU/P/MS

## 注意事项 Notes

### 1. 引脚使用注意事项 Lead Forming

- ✓ 在折弯胶体时候，必须距离胶体底部3mm处，才能折弯。  
During lead formation, the leads should be bent at a point at least 3mm from the base of the epoxy bulb.
- ✓ 支架成型必须在焊钳接前完成。  
Lead forming should be done before soldering.
- ✓ 在焊接的期间，不可以重压LED胶体，这样会损坏LED特性甚至造成死灯。  
Avoid stressing the LED package during leads forming. The stress to the base may damage the LED's characteristics or it may break the LEDs.
- ✓ 请在室温下切脚，高温下切脚可能会导致LED灯饰失效。  
Cut the LED leadframes at room temperature. Cutting the leadframes at high temperatures may cause failure of the LEDs.
- ✓ 在PCB上焊接LED时，PCB孔 必须与LED引脚精确对准，如果在安装后有应力作用在LED支架上面，可能会导致LED胶体松动，从而影响LED的产品质量。  
When mounting the LEDs onto a PCB, the PCB holes must be aligned exactly with the lead position of the LED. If the LEDs are mounted with stress at the leads, it causes deterioration of the epoxy resin and this will degrade the LEDs.

### 2. 存储 Storage

- ✓ LED发货后，应储存在温度低于30°，湿度低于70%的环境中，储存期限为3个月，如果LED储存在充满氮气和吸湿材料的密闭容器里，储存时间可达一年。  
The LEDs should be stored at 30°C or less and 70%RH or less after being shipped from Infinity and the storage life limits are 3 months. If the LEDs are stored for 3 months or more, they can be stored for a year in a sealed container with a nitrogen atmosphere and moisture absorbent material.
- ✓ 请避免急速降温，特别是高温高湿环境下急速降温，可能会发生结块现象。  
Please avoid rapid transitions in ambient temperature, especially, in high humidity environments where condensation can occur.

### 3. 焊接 Soldering

- ✓ 焊接位置应在距离胶体底部3mm以上处，建议在卡点下方焊接。  
Careful attention should be paid during soldering. When soldering, leave more than 3mm from solder joint to epoxy bulb, and soldering beyond the base of the tie bar is recommended.

#### 推荐焊接条件 Recommended soldering conditions:

手动焊接 Hand Soldering		自动插件 DIP Soldering	
烙铁头温度 Temp. at tip of iron	300°C Max. (30W Max.)	Preheat temp.	100°C Max. (60 sec Max.)
焊接温度 Soldering time	3 sec Max.	Bath temp. & time	260 Max., 5 sec Max
焊接距离 Distance	3mm Min. (From solder joint to epoxy bulb)	Distance	3mm Min. (From solder joint to epoxy bulb)

### 焊接温控曲线 Recommended soldering profile

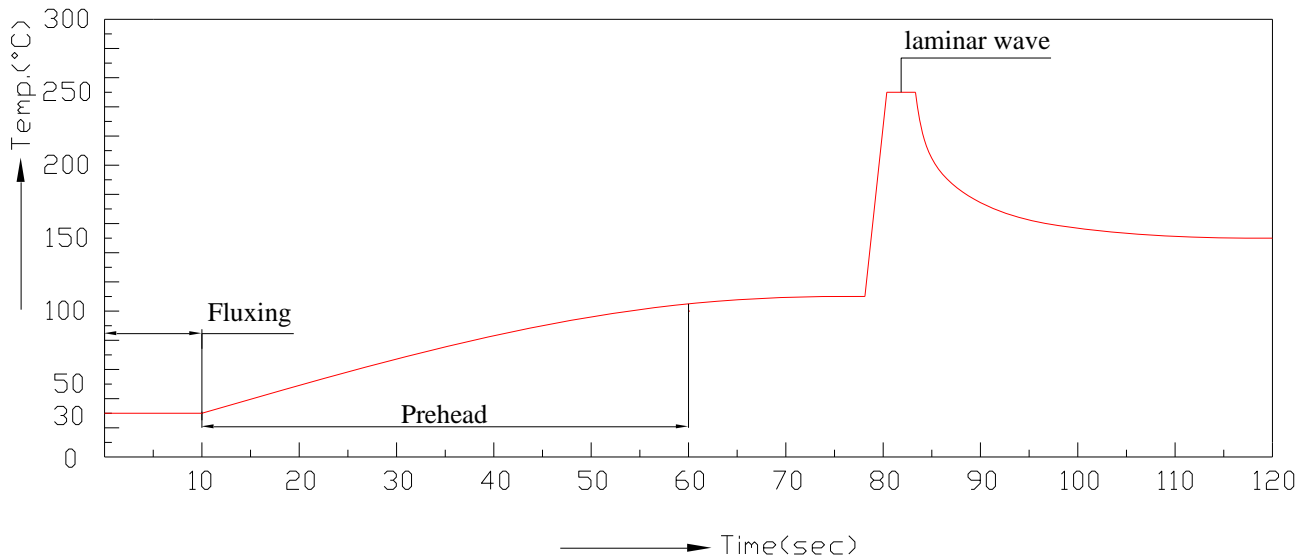

- ✓ 避免LED在高温下特别是焊接时对LED支架施加任何压力。  
Avoiding applying any stress to the lead frame while the LEDs are at high temperature particularly when soldering.
- ✓ 加工焊接不应超过一次。  
Dip and hand soldering should not be done more than one time
- ✓ 在LED焊接之后应保护胶体免受机械冲击或震动；直到LED胶体温度回到室温。  
After soldering the LEDs, the epoxy bulb should be protected from mechanical shock or vibration until the LEDs return to room temperature.
- ✓ 不推荐焊接后急速冷却LED。  
A rapid-rate process is not recommended for cooling the LEDs down from the peak temperature.
- ✓ 虽然推荐以上焊接条件，但是实际加工焊接时，尽可能的控制LED的焊接温度，这对LED无疑是非常有利的。  
Although the recommended soldering conditions are specified in the above table, dip or handsoldering at the lowest possible temperature is desirable for the LEDs.
- ✓ 波峰焊的参数必须根据推荐的温度和停留时间来设定。  
Wave soldering parameter must be set and maintain according to recommended temperature and dwell time in the solder wave.

#### 4. 清洗 Cleaning

- ✓ 必要时，尽在室温下用丙醇进行清洗，持续时间不超过1分钟。使用前室温干燥。  
When necessary, cleaning should occur only with isopropyl alcohol at room temperature for a duration of no more than one minute. Dry at room temperature before use.
- ✓ 不要用超声波清洗LED；如果无法避免时，请先确保超声波功率及其装备条件是可以清洗LED的，以确保不会对LED造成破坏。  
Do not clean the LEDs by the ultrasonic. When it is absolutely necessary, the influence of ultrasonic cleaning on the LEDs depends on factors such as ultrasonic power and the assembled condition. Ultrasonic cleaning shall be pre-qualified to ensure this will not cause damage to the LED.



# 738/YC3-RU/P/MS

### 5. 散热管理 Heat Management

- ✓ 在LED应用的设计时间，必须考虑LED的散热管理，请参考每个产品规格中的降温曲线，应适当的评估驱动电流。  
Heat management of LEDs must be taken into consideration during the design stage of LED application. The current should be de-rated appropriately by referring to the de-rating curve found in each product specification.
- ✓ 应用中的LED周围温度应加以控制，请参考降温曲线。  
The temperature surrounding the LED in the application should be controlled. Please refer to the data sheet de-rating curve.

### 6. 静电 ESD (Electrostatic Discharge)

- ✓ 静电放电或者尖波电流会对LED造成损坏。  
Electrostatic discharge (ESD) or surge current (EOS) can damage LEDs.
- ✓ 操作LED时，必须带静电手环，穿静电鞋、静电手套。  
An ESD wrist strap, ESD shoe strap or antistatic gloves must be worn whenever handling LEDs.
- ✓ 所有设备、仪器、机械装置必须正确接地。  
All devices, equipment and machinery must be properly grounded.
- ✓ 建议使用离子吹风机来中和，在搬运或者储存过程中胶体摩擦聚集在胶体上的电荷。  
Use ion blower to neutralize the static charge which might have built up on surface of the LEDs plastic lens as a result of friction between LEDs during storage and handing.

### 7. 其他 Other

- ✓ 以上规格如有变更，恕不另行通知，英利将保留对上述规格的材料变更权限。  
Above specification may be changed without notice. Infinity will reserve authority on material change for above specification.
- ✓ 请严格遵守产品使用说明中概述的使用规范，如果不按规范使用本产品造成不良或损失者，英利将不承担任何责任。  
When using this product, please observe the absolute maximum ratings and the instructions for using outlined in these specification sheets. Infinity assumes no responsibility for any damage resulting from use of the product which does not comply with the absolute maximum ratings and the instructions included in these specification sheets.
- ✓ 该规格书包含英利公司版权保护数据，任何人在未得到英利公司授权允许的情况下，不得复制。  
These specification sheets include materials protected under copyright of infinity's corporation. Please don't reproduce or cause anyone to reproduce them without Infinity's consent.