

INF-346

特性

Features

- 1、 超高亮度
High luminous intensity output
- 2、 橢圓形狀
Oval Shape
- 3、 完美的配光曲線
Well defined spatial radiation
- 4、 寬視角： 110°/ 50°
Wide viewing angle (2θ1/2) : 110°/50°
- 5、 抗UV老化膠體
UV resistant epoxy
- 6、 完全符合RoHs環保標準
The product itself will remain within RoHS compliant version

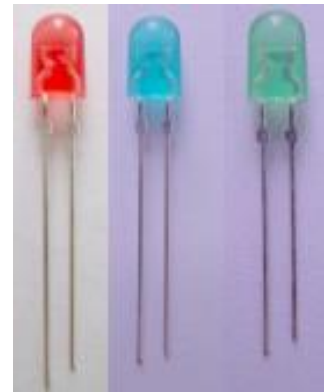

描述

Descriptions

此橢圓LED精密光學特性專門為可變情報看板設計
This precision optical performance oval LED is specifically designed for passenger information signs

應用範圍

Applications

- 1、 可變情報看板
Variable message Signs (VMS)
- 2、 戶外廣告屏
Commercial outdoor advertising

Device Selection Guide

NO.	材質 Material	發光顏色 Emitted Color	膠體顏色 Lens Color
红光/Red	磷化鋁鉀銻 AlGaInP	高亮紅光 Brilliant Red	紅色不透明 Red Diffused
綠光/Green	氮鉀銻 InGaN	綠色高亮 Brilliant Green	綠色不透明 Green Diffused

INF-346

蓝光/Blue	氮鉀鋼 InGaN	藍光 Blue	藍色不透明 Blue Diffused
---------	--------------	------------	------------------------

封裝尺寸

Package Dimensions

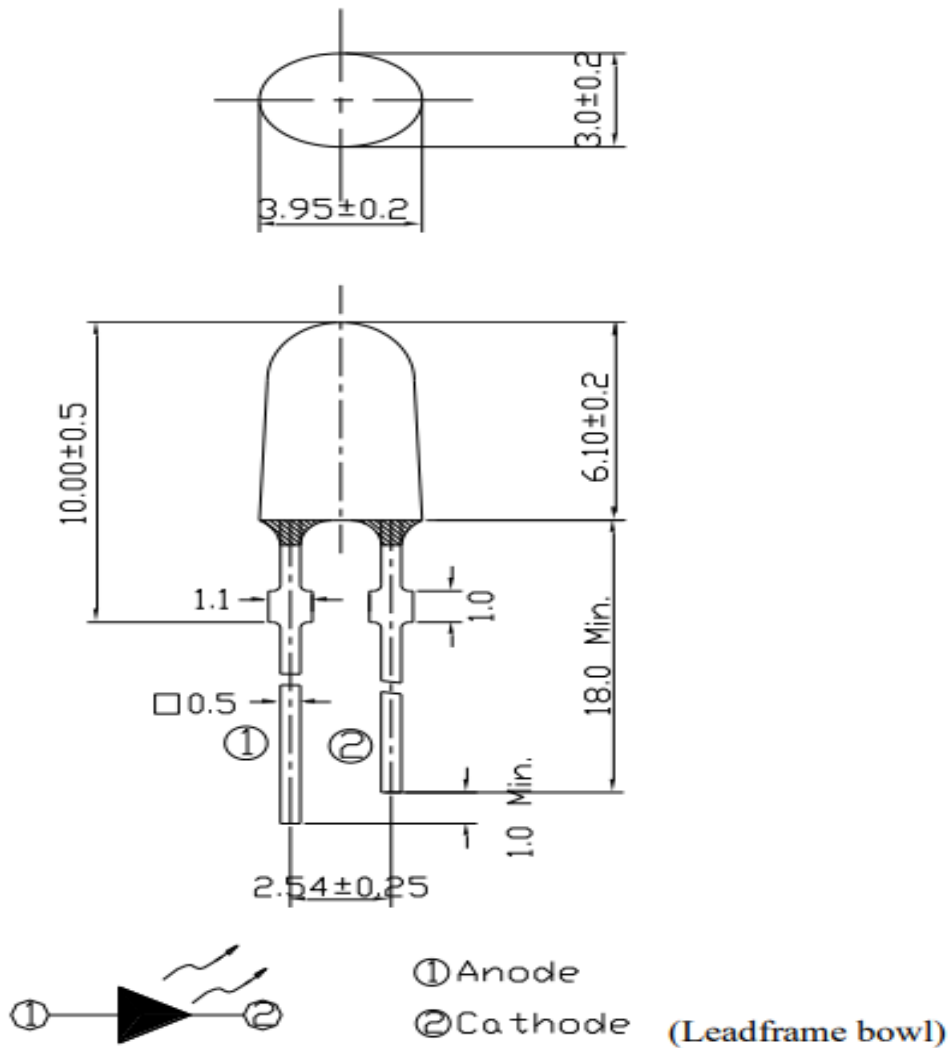

提示

Notes:

- 所有尺寸單位為：mm，公差為 ± 0.25 mm；指定除外。
All dimensions are in millimeters, tolerance is 0.25mm except being specified.

- 2、膠體底部與引腳處多膠最大不超過1.5mm。
Protruded resin under flange is 1.5mm Max LED.

● 極限參數(Ta=25°C)

Absolute Maximum Rating (Ta=25°C)

參數名稱 Parameter	符號 Symbol	最大極限數值 Absolute Maximum Rating	單位 Unit
正向電流 Forward Current	I _F	50	mA
脈衝電流 Pulse Forward Current (Duty1/10@ 1KHz)	I _{FP}	160	mA
工作溫度 Operating Temperature	T _{opr}	-40 ~ +85	°C
儲存溫度 Storage Temperature	T _{stg}	-40 ~ +100	°C
焊接溫度 Soldering Temperature	T _{sol}	260	°C
功耗 Power Dissipation	P _d	120	mW
反向電壓 Reverse Voltage	VR	5	V
抗靜電 Electrostatic Discharge	ESD	2K	V

提示 (Notes) : 焊接時間不可以超過 5 秒 (Soldering time ≤ 5 seconds) 。

● 光電特性(Ta=25°C)

Red Electro-Optical Characteristics (Ta=25°C)

參數名稱 Parameter	符號 Symbol	最小 Min.	規格 Typ.	最大 Max.	單位 Unit	測試條件 Condition
光強 Luminous Intensity	I _v	1440	--	2050	mcd	I _F =20mA
可視角度 Viewing Angle	2θ _{1/2}	--	X:105Y:50	--	deg	
波峰值 Peak Wavelength	λ _p	--	631	--	nm	
主波長 Dominant Wavelength	λ _d	619	624	628		

半波寬 Spectrum Half width	$\Delta \lambda$	--	20	--		
正向電壓 Forward Voltage	V_F	1.8	2.2	2.6	V	
反向電流 Reverse Current	I_R	--	--	10	μA	$V_R=5V$

Green Electro-Optical Characteristics (Ta=25°C)

參數名稱 Parameter	符號 Symbol	最小 Min.	規格 Typ.	最大 Max.	單位 Unit	測試條件 Condition
光強 Luminous Intensity	I_V	2880	--	4970	mcd	$I_F=20mA$
可視角度 Viewing Angle	$2\theta_{1/2}$	--	X:110Y:50	--	deg	
波峰值 Peak Wavelength	λ_p	--	522	--	nm	
主波長 Dominant Wavelength	λ_d	525	530	535		
半波寬 Spectrum Half width	$\Delta \lambda$	--	35	--		
正向電壓 Forward Voltage	V_F	2.8	--	3.6	V	
反向電流 Reverse Current	I_R	--	--	10	μA	$V_R=5V$

Blue Electro-Optical Characteristics (Ta=25°C)

參數名稱 Parameter	符號 Symbol	最小 Min.	規格 Typ.	最大 Max.	單位 Unit	測試條件 Condition
光強 Luminous Intensity	I_V	880	--	1250	mcd	$I_F=20mA$
可視角度 Viewing Angle	$2\theta_{1/2}$	--	X:110Y:50	--	deg	
波峰值 Peak Wavelength	λ_p	--	468	--	nm	
主波長 Dominant Wavelength	λ_d	465	470	475		
半波寬 Spectrum Half width	$\Delta \lambda$	--	26	--		
正向電壓 Forward Voltage	V_F	2.8	--	3.6	V	
反向電流 Reverse Current	I_R	--	--	10	μA	$V_R=5V$

● 光強度等級範圍

Bin Range of Luminous Intensity

红光/Red

等級 Bin Code	最小值 Min	最大值 Max	單位 Unit	測試條件 Condition
J1	1440	1720	mcd	I _F =20mA
J2	1720	2050		

綠光/Green

等級 Bin Code	最小值 Min	最大值 Max	單位 Unit	測試條件 Condition
M1	2880	3450	mcd	I _F =20mA
M2	3450	4140		
N1	4140	4970		

藍光/Blue

等級 Bin Code	最小值 Min	最大值 Max	單位 Unit	測試條件 Condition
G2	880	1050	mcd	I _F =20mA
H1	1050	1250		

*Measurement Uncertainty of Luminous Intensity: ±5%

● 波長等級範圍

Bin Range of Dominant Wavelength

红光/Red

等級 Bin Code	最小值 Min	最大值 Max	單位 Unit	測試條件 Condition
a	620	624	nm	I _F =20mA
b	624	628		

绿光/Green

等級 Bin Code	最小值 Min	最大值 Max	單位 Unit	測試條件 Condition
a	525	530	nm	I _F =20mA
b	530	535		

蓝光/Blue

等級 Bin Code	最小值 Min	最大值 Max	單位 Unit	測試條件 Condition
a	460	465	nm	I _F =20mA
b	465	470		

*Measurement Uncertainty of Dominant Wavelength $\pm 1.0\text{nm}$

● 電壓等級範圍（僅供參考，不做分 bin）

Bin Range of Forward Voltage

红光/Red

等級 Bin Code	最小值 Min	最大值 Max	單位 Unit	測試條件 Condition
V1	1.8	2.0	V	I _F =20mA
V2	2.0	2.2		
V3	2.2	2.4		

绿光/Green

等級 Bin Code	最小值 Min	最大值 Max	單位 Unit	測試條件 Condition
V1	2.8	3.0	V	I _F =20mA
V2	3.0	3.2		
V3	3.2	3.4		
V4	3.4	3.6		

蓝光/Blue

等級 Bin Code	最小值 Min	最大值 Max	單位 Unit	測試條件 Condition
V1	2.8	3.0	V	I _F =20mA
V2	3.0	3.2		
V3	3.2	3.4		

V4	3.4	3.6	
----	-----	-----	--

*Measurement Uncertainty of Forward Voltage: $\pm 0.1V$

● 典型特性曲線

Typical Electro-Optical Characteristics Curves

红光/Red

Relative Intensity vs. Wavelength

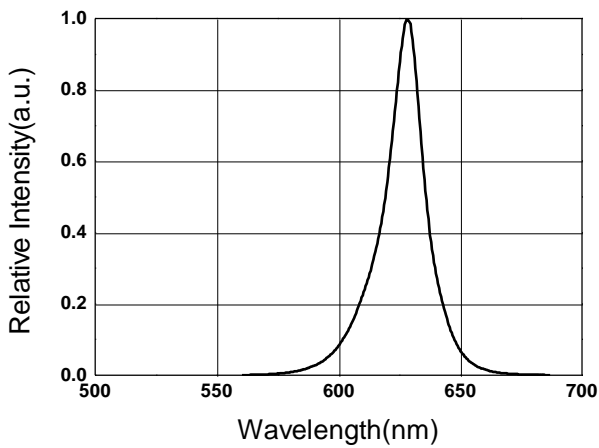

Forward Current vs. Forward Voltage

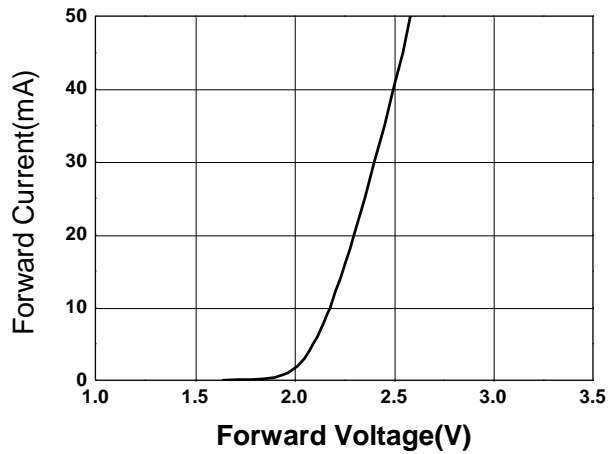

Relative Intensity vs. Ambient Temp.

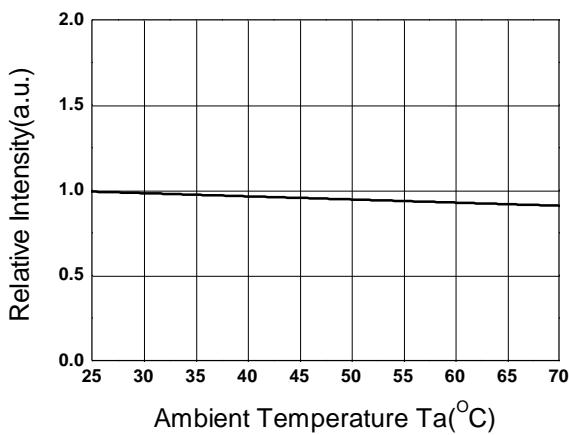

Relative Intensity vs. Forward Current

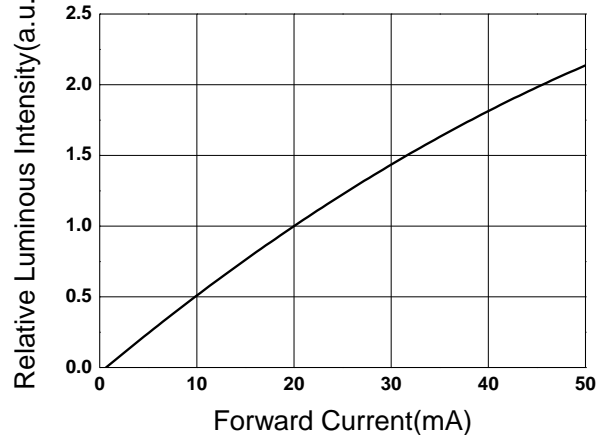

Forward Current vs. Ambient Temp.

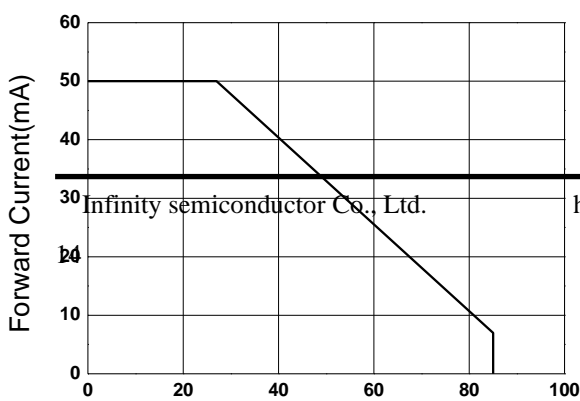

Radiation Characteristics

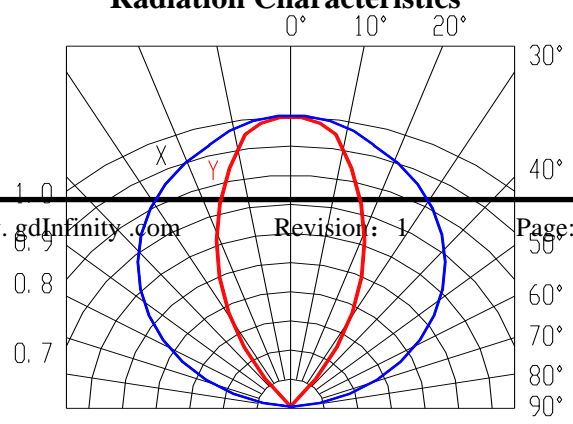

绿光/Green

Relative Intensity vs. Wavelength

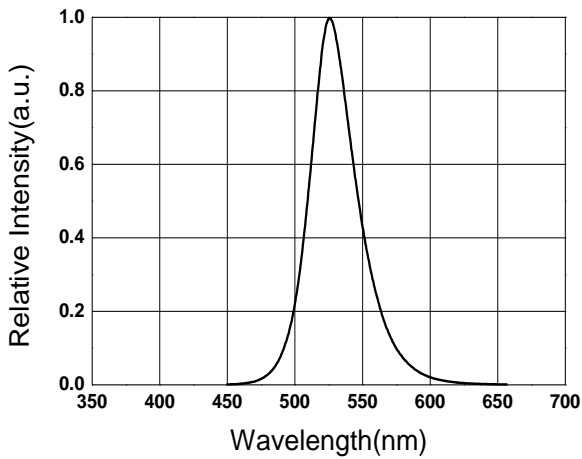

Forward Current vs. Forward Voltage

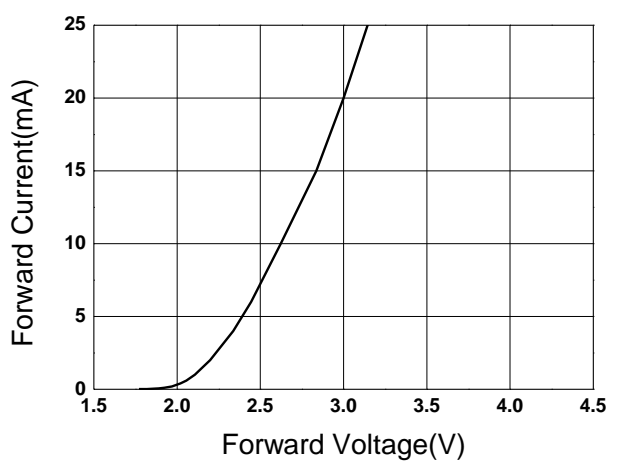

Relative Intensity vs. Ambient Temp.

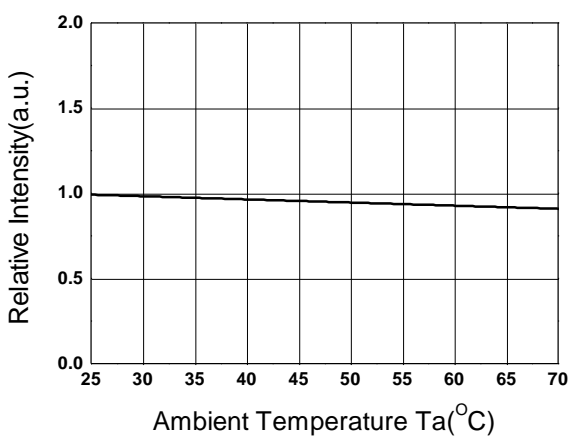

Relative Intensity vs. Forward Current

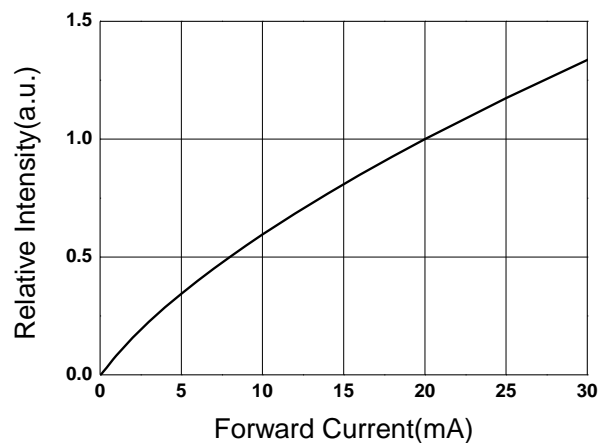

Forward Current vs. Ambient Temp.

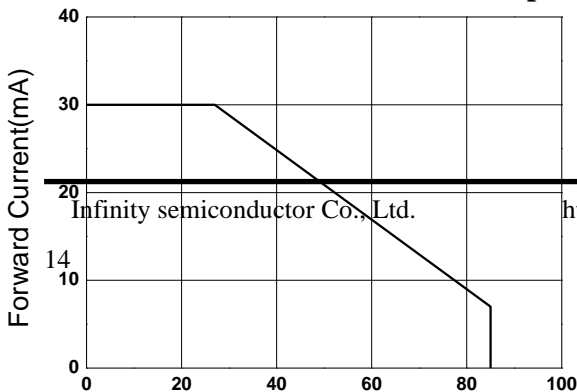

Radiation Characteristics

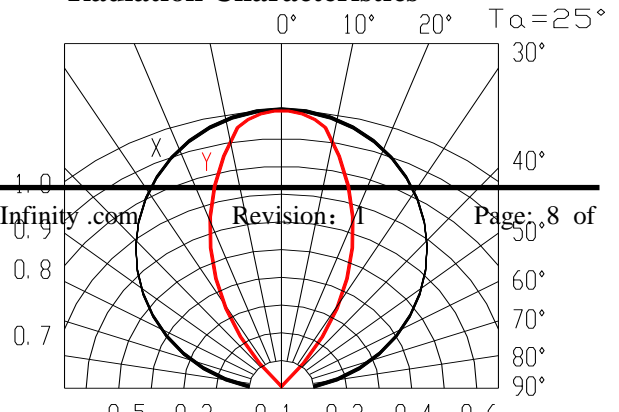

蓝光/Blue

Relative Intensity vs. Wavelength

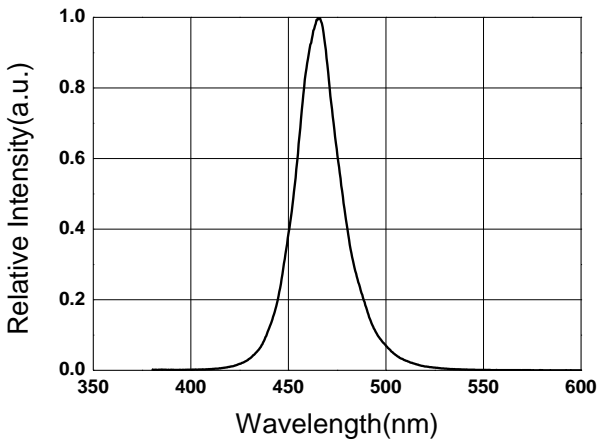

Forward Current vs. Forward Voltage

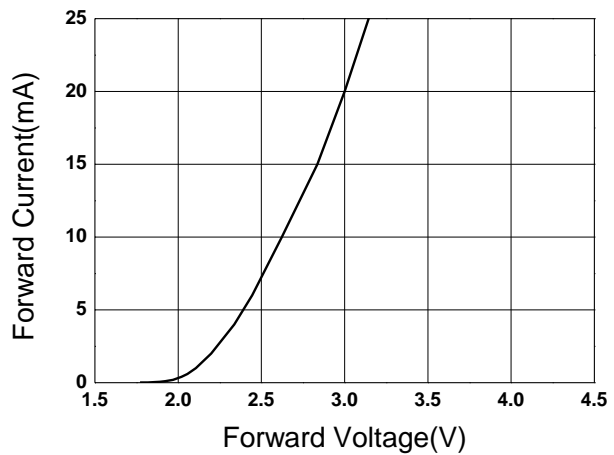

Relative Intensity vs. Ambient Temp.

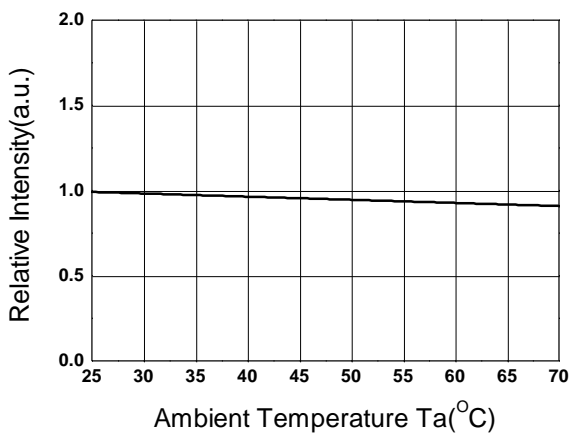

Relative Intensity vs. Forward Current

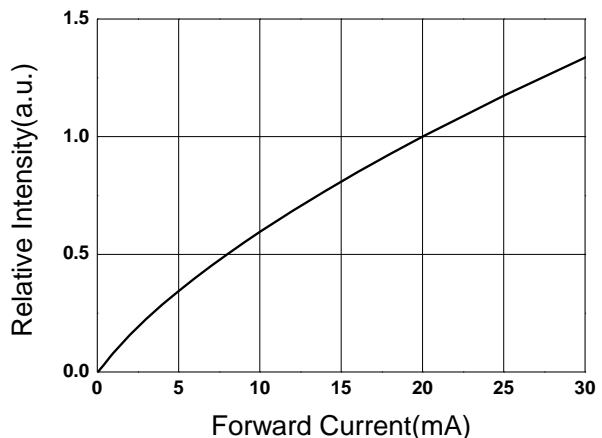

Forward Current vs. Ambient Temp.

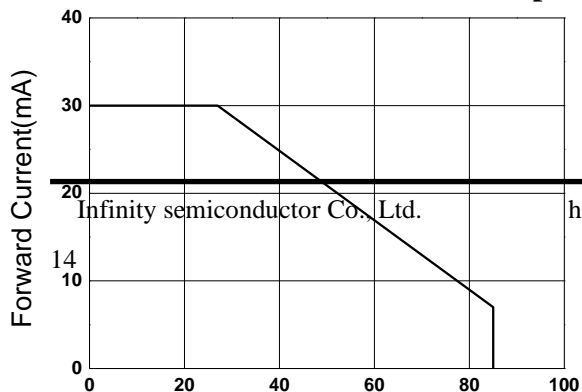

Radiation Characteristics

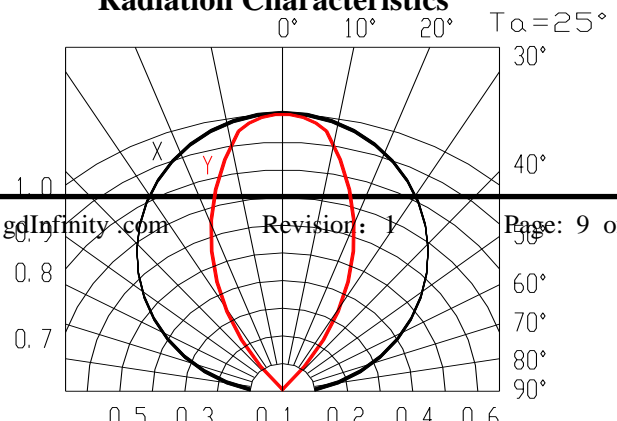

● 包裝規格說明
Packing Specification

■ 靜電包裝袋 Anti-electrostatic bag

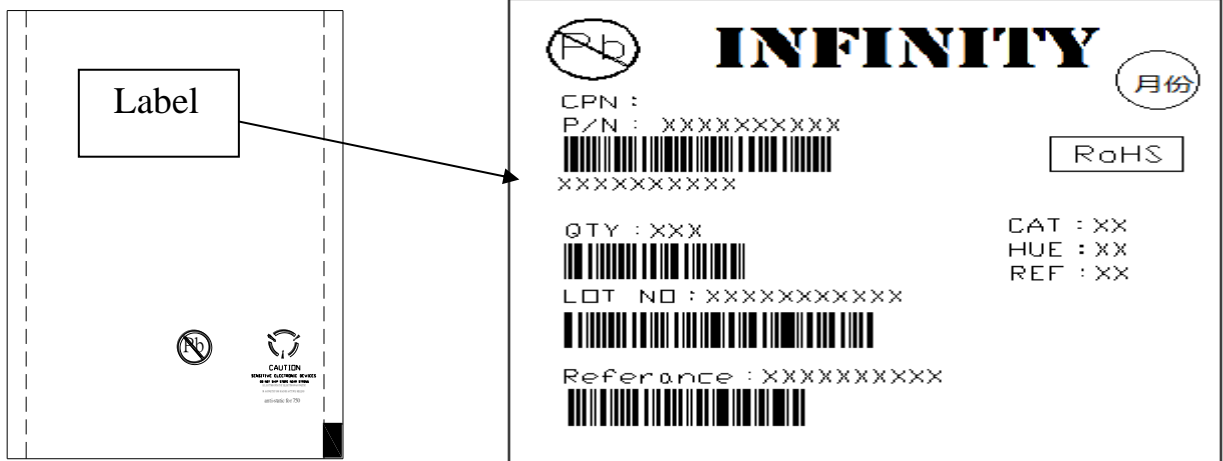

包裝試樣說明 (Label Form Specification)

客戶物料編號

CPN: Customer's Production Number

英利物料代碼

P/N : Production Number

包裝數量

QTY: Packing Quantity

光強等級範圍

CAT: Ranks of Luminous Intensity and Forward Voltage

波長等級範圍

HUE: Rank of Dominant Wavelength

追蹤代碼

REF: Reference

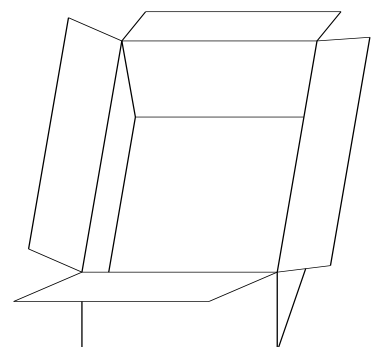

批次號

LOT No: Lot Number

內盒 Inner Carton

外盒 Outside Carton

包裝數量說明

Packing Quantity

- 1、 內盒 3500pcs 一盒
3500 PCS /1 Inner Carton
- 2、 一箱包含十小盒
10 Inner Cartons/1 Outside Carton

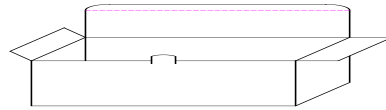

注意事項

Notes

1. 引腳使用注意事項

Lead Forming

- ✓ 在折彎膠體時候，必須距離膠體底部3mm處，才能折彎
During lead formation, the leads should be bent at a point at least 3mm from the base of the epoxy bulb.
- ✓ 支架成型必須在焊鉗接前完成
Lead forming should be done before soldering.
- ✓ 在焊接的期間，不可以重壓LED膠體，這樣會損壞LED特性甚至造成死燈
Avoid stressing the LED package during leads forming. The stress to the base may damage the LED's characteristics or it may break the LEDs.
- ✓ 請在室溫下切腳，高溫下切腳可能回導致LED燈飾失效
Cut the LED leadframes at room temperature. Cutting the leadframes at high temperatures may cause failure of the LEDs.
- ✓ 在PCB上焊接LED時，PCB孔必須與LED引腳精確對準，如果在安裝後有應力作用在LED支架上面，可能會導致LED膠體鬆動，從而影響LED的產品品質
When mounting the LEDs onto a PCB, the PCB holes must be aligned exactly with the lead position of the LED. If the LEDs are mounted with stress at the leads, it causes deterioration of the epoxy resin and this will degrade the LEDs.

2. 存儲

Storage

- ✓ LED發貨后，應儲存在溫度低於30°，濕度低於70%的環境中，儲存期限為3個月，如果LED儲存在充滿氮氣和吸濕材料的密閉容器里，儲存時間可達一年。
The LEDs should be stored at 30°C or less and 70%RH or less after being shipped from Infinity and the storage life limits are 3 months. If the LEDs are stored for 3 months or more, they can be stored for a year in a sealed container with a nitrogen atmosphere and moisture absorbent material.

- ✓ 請避免急速降溫，特別是高溫高濕環境下急速降溫，可能回發生結塊現象
Please avoid rapid transitions in ambient temperature, especially, in high humidity environments where condensation can occur.

3. 焊接

Soldering

- ✓ 焊接位置應在距離膠體底部3mm以上處，建議在卡點下方焊接
Careful attention should be paid during soldering. When soldering, leave more than 3mm from solder joint to epoxy bulb, and soldering beyond the base of the tie bar is recommended.

- 推薦焊接條件

Recommended soldering conditions:

手動焊接 Hand Soldering		自動插件 DIP Soldering	
烙鐵頭溫度 Temp. at tip of iron	300°C Max. (30W Max.)	Preheat temp.	100°C Max. (60 sec Max.)
焊接溫度 Soldering time	3 sec Max.	Bath temp. & time	260 Max., 5 sec Max
焊接距離 Distance	3mm Min. (From solder joint to epoxy bulb)	Distance	3mm Min. (From solder joint to epoxy bulb)

- 焊接溫控曲線

Recommended soldering profile

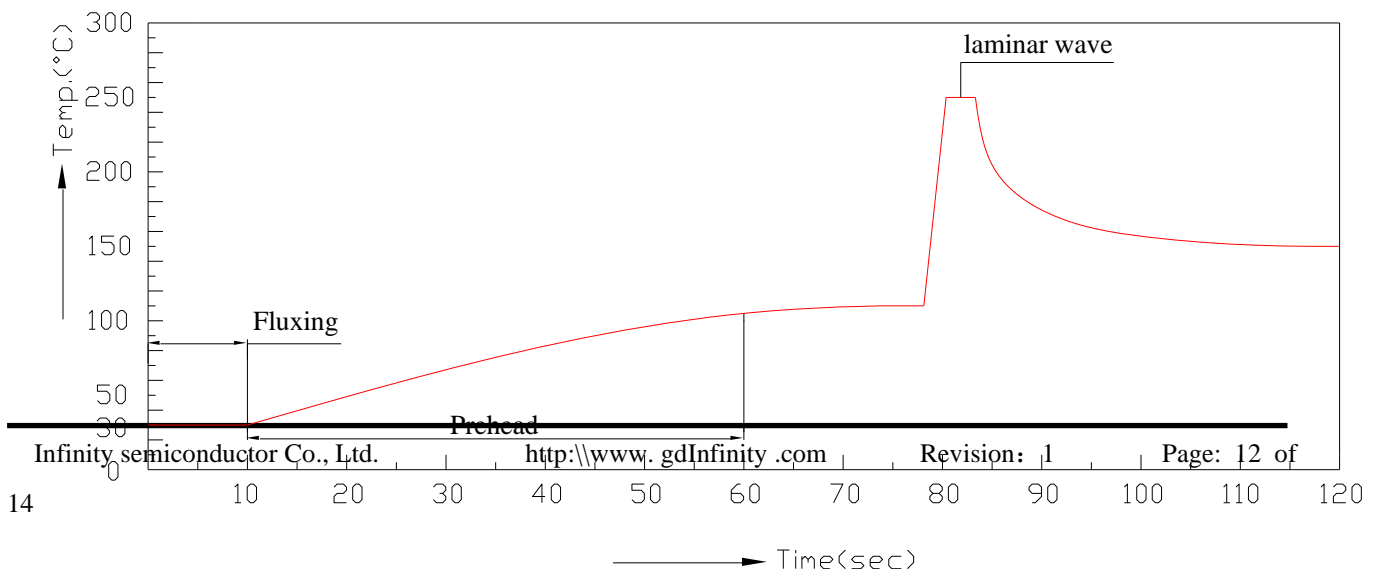

- ✓ 避免LED在高溫下特別是焊接時對LED支架施加任何壓力
Avoiding applying any stress to the lead frame while the LEDs are at high temperature particularly when soldering.
- ✓ 加工焊接不應超過一次
Dip and hand soldering should not be done more than one time
- ✓ 在LED焊接之後應保護膠體免受機械衝擊或震動；直到LED膠體溫度回到室溫
After soldering the LEDs, the epoxy bulb should be protected from mechanical shock or vibration until the LEDs return to room temperature.
- ✓ 不推薦焊接后急速冷卻LED
A rapid-rate process is not recommended for cooling the LEDs down from the peak temperature.
- ✓ 雖然推薦以上焊接條件，但是實際加工焊接時，盡可能的控制LED的焊接溫度，這對LED無疑是非常有利的。
Although the recommended soldering conditions are specified in the above table, dip or handsoldering at the lowest possible temperature is desirable for the LEDs.
- ✓ 波峰焊的參數必須根據推薦的溫度和停留時間來設定
Wave soldering parameter must be set and maintain according to recommended temperature and dwell time in the solder wave.

4. 清洗

Cleaning

- ✓ 必要時，盡在室溫下用丙醇進行清洗，持續時間不超過1分鐘。使用前室溫乾燥
When necessary, cleaning should occur only with isopropyl alcohol at room temperature for a duration of no more than one minute. Dry at room temperature before use.
- ✓ 不要用超聲波清洗LED；如果無法避免時，請先確保超聲波功率及其裝備條件是可以清洗LED的，以確保不會對LED造成破壞。
Do not clean the LEDs by the ultrasonic. When it is absolutely necessary, the influence of ultrasonic cleaning on the LEDs depends on factors such as ultrasonic power and the assembled condition. Ultrasonic cleaning shall be pre-qualified to ensure this will not cause damage to the LED

5. 散熱管理

Heat Management

- ✓ 在LED應用的設計階段，必須考慮LED的散熱管理，請參考每個產品規格中的降溫曲線，應適當的評估驅動電流。
Heat management of LEDs must be taken into consideration during the design stage of LED

application. The current should be de-rated appropriately by referring to the de-rating curve found in each product specification.

- ✓ 應用中的LED周圍溫度應加以控制，請參考降溫曲線

The temperature surrounding the LED in the application should be controlled. Please refer to the data sheet de-rating curve.

6. 靜電

ESD (Electrostatic Discharge)

- ✓ 靜電放電或者尖波電流會對LED造成損壞

Electrostatic discharge (ESD) or surge current (EOS) can damage LEDs.

- ✓ 操作LED時，必須帶靜電手環，穿靜電鞋、靜電手套

An ESD wrist strap, ESD shoe strap or antistatic gloves must be worn whenever handling LEDs.

- ✓ 所有設備、儀器、機械裝置必須正確接地

All devices, equipment and machinery must be properly grounded.

- ✓ 建議使用離子吹風機來中和，在搬運或者儲存過程中膠體摩擦聚集在膠體上的電荷。

Use ion blower to neutralize the static charge which might have built up on surface of the LEDs plastic lens as a result of friction between LEDs during storage and handing.

7. 其他

Other

- ✓ 以上規格如有變更，恕不另行通知，英利將保留對上述規格的材料變更權限

Above specification may be changed without notice. Infinity will reserve authority on material change for above specification.

- ✓ 請嚴格遵守產品使用說明中概述的使用規範，如果不按規範使用本產品造成不良或損失者，英利將不承擔任何責任。

When using this product, please observe the absolute maximum ratings and the instructions for using outlined in these specification sheets. Infinity assumes no responsibility for any damage resulting from use of the product which does not comply with the absolute maximum ratings and the instructions included in these specification sheets.

- ✓ 該規格書包含英利公司版權保護資料，任何人在未得到英利公司授權允許的情況下，不得複製

These specification sheets include materials protected under copyright of infinity's corporation. Please don't reproduce or cause anyone to reproduce them without Infinity's consent.